

# Washer extractor

## W575N

### Features and benefits

- **Compass Pro<sup>®</sup> microprocessor offers:**
  - Large display and one control knob for easy program selection
  - Language selection
  - Quick selection and option buttons for the most frequently used wash programs and options
  - Wash program packages optimized on Economy, Performance and Time. (Available on general programs)
- Extremely low water and energy consumption – see table below
- Four compartment detergent box for manual dosing of powder or liquid detergent
- High extraction force for efficient dewatering
- Door with gasket and strong hinges built for heavy duty operation
- Stainless and galvanized steel in all vital parts for high degree of rust protection
- SuperBalance guarantees the correct extraction force

### Main options

- Automatic liquid detergent supply (optional I/O board)
- Stainless steel front panel
- Connection to booking- /payment- system or coin meter
- Drain pump



Images shown are a representation of the product only and variations may occur.

Main specifications				W575N			
Max. capacity	filling factor 1:9	kg/lb		8/18			
Drum, volume		litre		75			
	diameter	ø mm		520			
Extraction		rpm		587			
G-factor				100			
Standard heating alternatives	electricity	kW		5.4 / 7.5			
Low energy heating alternatives	electricity	kW		2.0 / 3.0			
	steam			X			
	non-heated			X			
<b>Consumption data "Normal 60°C"</b>				EI		Steam**	
<b>Economy*</b>				Full load, 8 kg	Half load, 4 kg	Full load, 8 kg	Half load, 4 kg
Total time		min	44	42	44	42	
Water consumption (cold+hot)		litre	47+13	37+8	60+0	45+0	
Energy consumption (motor/heating/hot water)		kWh	0.1/0.35/0.8	0.1/0.25/0.45	0.1/-	0.1/-	
Steam consumption		kg	-	-	1.75	1.05	
Residual moisture		%	69	78	69	78	

\* Water temperature 15°C cold water and 65°C hot water.

\*\* Depending on steam pressure.

Electrical connections*					
Heating alternative	Main voltage		Heating power kW	Total power kW	Recommended fuse A
		Hz			
Electric heated	220-240V 1 -	50/60	5.4/7.5	5.7/7.8	25/35
	220-240V 1 -	50/60	2.0/3.0	2.3/3.3	16
	220-240V 3 -	50/60	5.4/7.5	5.7/7.8	16/25
	380-415V 3N -	50/60	5.4/7.5	5.7/7.8	10/16
	440V 3 -	60	7.5	7.8	16
	480V 3 -	60	7.5	7.8	16
Steam or Non heated	220-480V 1 -	50/60	-	0.4	10

Water and steam connection		W575N
Water valves	DN	20
Water pressure	kPa	200-600
Capacity at 300 kPa	l/min	20
Drain valve	∅ mm	75
Draining capacity	l/min	170
Steam valve	DN	15
Steam pressure	kPa	300-600
Liquid detergent supplies		5
Floor requirements		
Frequency of the dynamic force	Hz	9.8
Floor load at max extraction	kN	1.6 ± 1.9
Sound levels		
Sound power level (IEC 60704-2-4)		
wash	dB(A)	65
extraction	dB(A)	69
Heat emission		
% of installed power, max		5
Shipping data**		
Weight	net, kg	116
Shipping volume	m <sup>3</sup>	0.75
Accessories		
Steel base		x
Hose kits for water or steam		x
Fluff collector		x
Dimensions in mm		
A Width		660
B Depth		681
C Height		1131
D		409
E		1099
F		835
G		80
H		1034
I		217
J		124
K		1014
L		914
M		278
N		101
O		199
1 Operating panel	7 Drain	
2 Door opening ∅ 310 mm	8 Liquid detergent supply	
3 Detergent box	9 Electrical connection	
4 Cold water	10 Steam connection	
5 Hot water		
6 Re-used water		

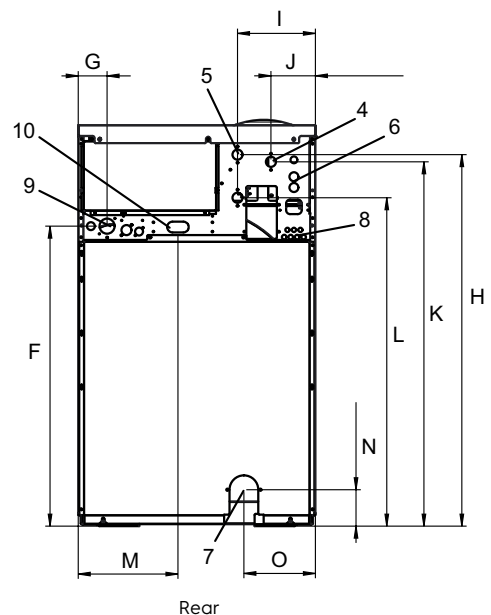
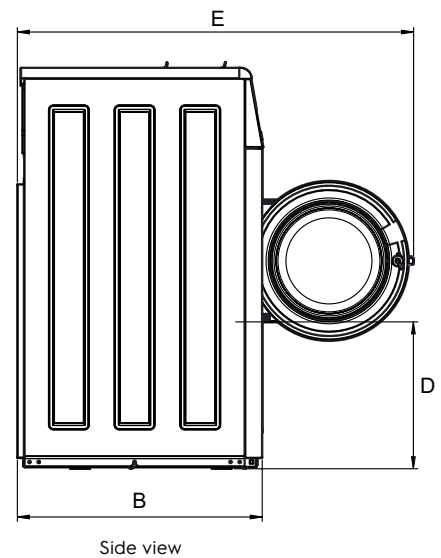
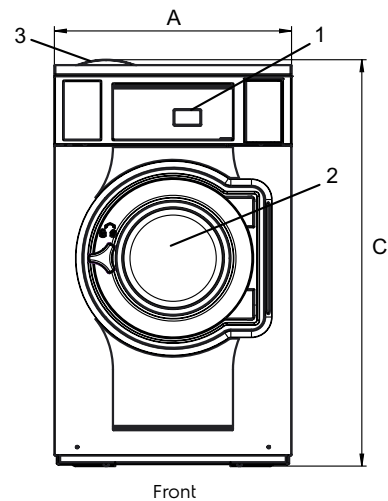

Front and side panels in light grey and blue (RAL 260 70 05, 250 60 30)

\* Other voltages available, see installation manual

\*\* Average data. Crated weight/shipping volume depends on configuration. Please contact logistics for exact measures.